

# LUBRICATION

## ORDER

**L05-4310-221-15**

17 APRIL 1962 (Supersedes L05-4310-221-15, 7 August 1961)

**COMPRESSOR, ROTARY: AIR; SKID MTD; GASOLINE  
DRIVEN; 125 CFM 100 PSI (INGERSOLL-RAND  
MODEL GER-125) W/CONTINENTAL  
ENGINE MODEL FS-162**

Reference: SM 10-1-C4-1

Intervals are based on normal operation. Reduce to compensate for abnormal operations and severe conditions. During inactive periods sufficient lubrication must be performed for adequate preservation.

Clean fittings before lubricating.

Relubricate after washing.

Clean parts with SOLVENT, dry-cleaning, or with OIL, fuel, Diesel. Dry before lubricating.

Dotted circle indicates drain below.

Drain crankcase only when hot after operation; replenish and check level when cool.

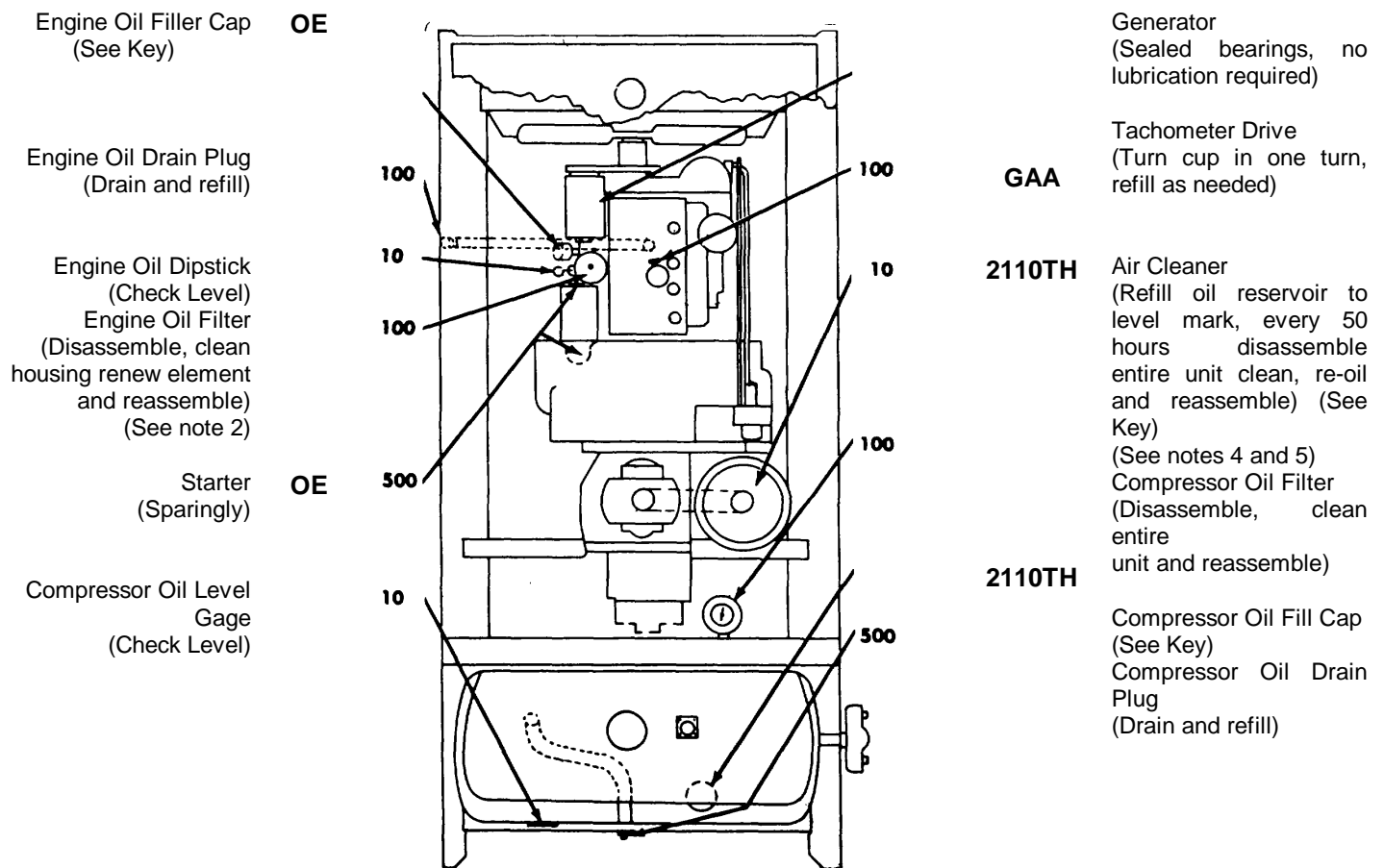

**KEY**

LUBRICANTS	CAPACITY	EXPECTED TEMPERATURES			INTERVALS
		Above +32°F	+40°F to 10°F	0°F to 65°F	
<b>OE</b> —OIL, Engine, Heavy Duty					
Engine Crankcase	4—1/2 qt	<b>OE 30</b> or <b>9250</b>	<b>OE 10</b> or <b>9110</b>	<b>OES</b>	
Oil Can Paints					
<b>OES</b> —OIL, Engine, Subzero					
<b>2110TH</b> —LUBRICATING OIL, General Purpose					<b>Intervals</b>
Compressor Air Receiver	20 qt				<b>given are</b>
Air Cleaner (See note 4)	1—3/4 qt	<b>2110TH</b>	<b>2110TH</b>	<b>OES</b>	<b>in hours of</b>
Air Cleaner (See note 5)	3 1/4 qt				<b>normal</b>
<b>GAA</b> —GREASE, Automotive and Artillery					<b>operation</b>

**NOTES:**

1. FOR OPERATION OF EQUIPMENT IN PROTRACTED COLD TEMPERATURES BELOW -10°F. Remove lubricants prescribed in the key for temperatures above -10°F. Clean parts with SOLVENT, drycleaning. Relubricate with lubricants specified in the key for temperatures below -10°F.

2. OIL FILTER. After installing new filter elements, fill crankcase, operate engine 5 minutes, check housings for leaks, check crankcase oil level and bring to full mark.

3. OIL CAN POINTS. Every 50 hours clean and lightly coat control linkages, exposed threads and pins with OE.

**FOLD**

4. AIR CLEANER. Capacity shown is applicable to end items within serial number range 125CR22346 inclusive.

5. AIR CLEANER. Capacity shown is applicable to end items within serial number range 125CR24901 thru 125CR25400 inclusive.

Copy of this Lubrication Order will remain with the equipment at all times; instructions contained herein are mandatory.

**FOLD**

BY ORDER OF THE  
SECRETARY OF THE ARMY:

G. H. DECKER,  
*General, United States Army*  
*Chief of Staff*

Official:

J. C. LAMBERT,  
*Major General, United States Army,*  
*The Adjutant General.*

LO 5-4310-221-15 DISTRIBUTION: Active Army USASA (2); DCSLOG (1); CNGB (1); Tech Stf, DA (1) except CofEngrs (3); Army Maint Bd (1); USCONARC (3); USAARTYBD (2); USAARTYBD (2); USAIB (2); USARDB (2); USAABELCTBD (2); USAAVNBD (2); ARADCOM (2); ARADCOM Rgn (2); OS Maj Comd (5) except USASETAP (2). USARJ (10); MDW (1); Armies (2); Corp (2)1 Div (2); Engr Bde (1); Svc Colleges (2); Br Svc Sch (2) except USAES (100); USMA (2); GENDEP (2) except Schenectady GENDEP (4), Atlanta GENDEPP (4); Utah GENDEP (4); Memphis GENDEP (4); Sharpe GENDEP (4) Engr Sec GENDEP (10); except Granite City Engr Dep (14); USA Trans Tml Comd (2); Army Tml (1); OSA (2); Engr Dist (2) except Buffalo Engr Dist (1), Chicago Engr Dist (1), Detroit Engr Dist (1), Alaska Engr Dist (1); Los Angeles Engr Dist (1), New Orleans Engr Dist (1), New York Engr. Dist (1), Louisville Engr Dist (1), Pittsburgh Engr Dist (1), San Francisco Engr Dist (1). Omaha Engr Dist (1), Seattle Engr Dist (1), Kansas City Engr Dist (1), Baltimore Engr Dist (1), Ft Worth Engr Dist (1), Eastern Ocean Engr Dist (1), Philadelphia Engr Dist (1), Rock Island Engr Dist (1), St Louis Engr Dist (1), St Paul Engr Dist (1); Div Engr (2) except Lower Miss Valley Div (None); Engr Fld Maint Shops (2); Engr Dep Main Shops (2); USAERDL (3); Engr Cen (5); AMS (3); USA Engr Proc Ofc (10); EMC (10); Fld Comd, DASA (8); Def Log Sc Cen (10); USACOMZEUR (2); 5-114 (2); 5-237 (5); 5-262 (5); 5-267 (1); 5-278 (5); 5-279 (2); 6-627 (2); 8-187 (2); 9-377 (2); 9-510 (df, DG) (2); 39-51 (20: 55-225 (2); 55-227 (2); 55-237 (2); 55-247 (2); 55-500 (IE) (2). NG; State AG (3), USAR: Same as Active Army except allowance is one copy to each unit. For explanation of abbreviations used, see AR 320-50.